

Betz ColorTrans

ink supply systems for sheet-fed presses



Betz ColorPump Ink pumps

Depending on the performance of your presses we have the right ink pump

Pail can pump P100/113-25H
Delivery/double stroke 113 cm³
Pressure ratio 21 : 1



Drum pump P100/113-2L
Delivery/double stroke 113 cm³
Pressure ratio 21 : 1

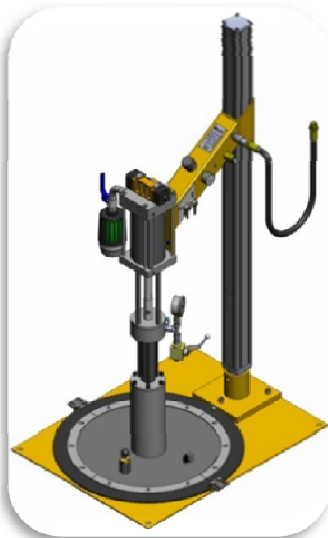

Drum pump P200/329-2L
Delivery/double stroke 329 cm³
Pressure ratio 30 : 1

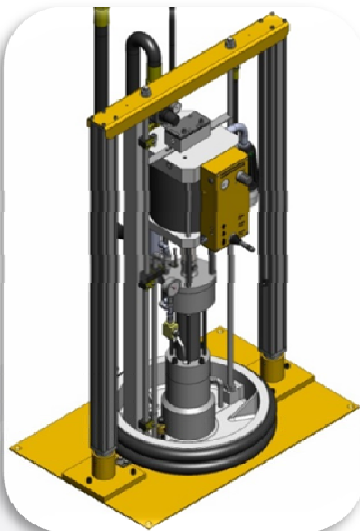
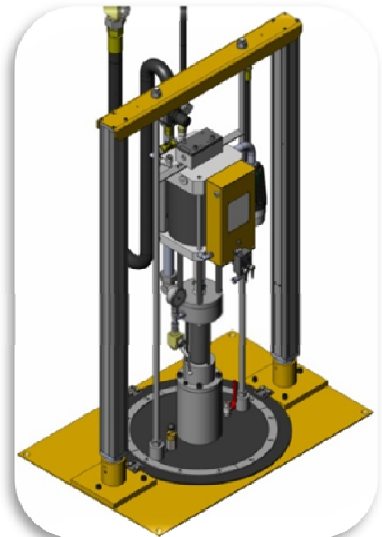

Drum pump P200/329-2L/DH
Delivery/double stroke 329 cm³
Pressure ratio 30 : 1



Drum pump P100/150-2/L/UV
Delivery/double stroke 150 cm³
Pressure ratio 8 : 1

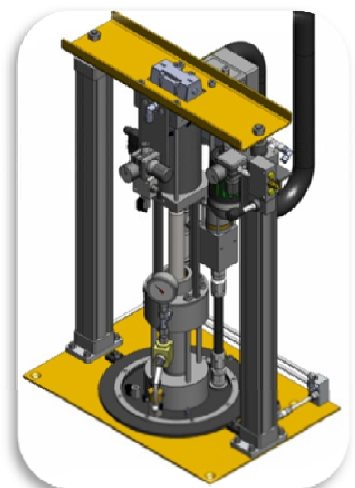

Pail can pump P100/150-25H/L/UV
Delivery/double stroke 113 cm³
Pressure ratio 8 : 1

Betz ColorTrans ink supply

Ink dispensing desk made of stainless steel to fill the ink into 2.5 kg ink cans with pipe work and 4 pneumatic drum pumps.

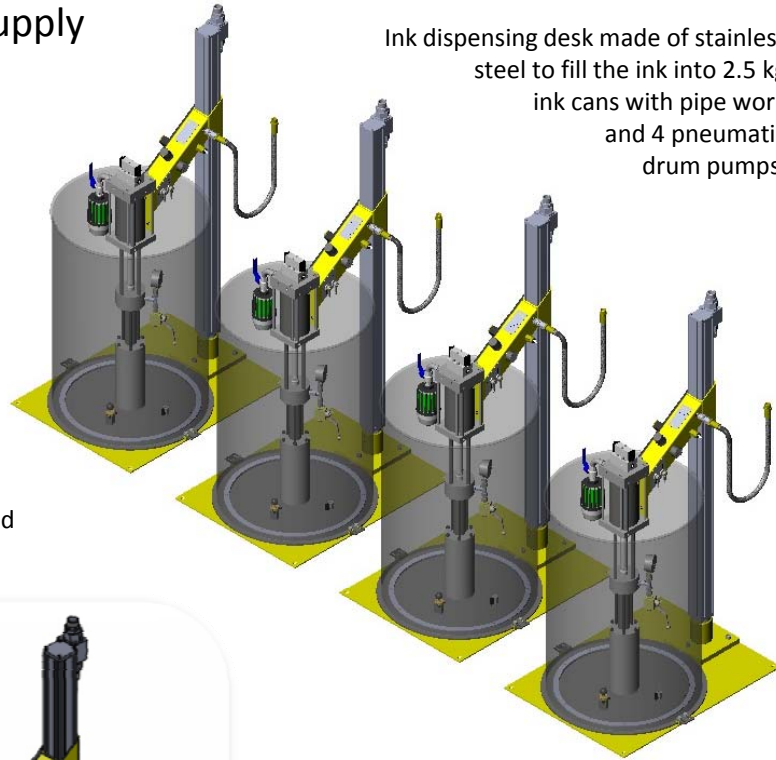

Single Ink dispensing stand for 2.5 kg cans manual

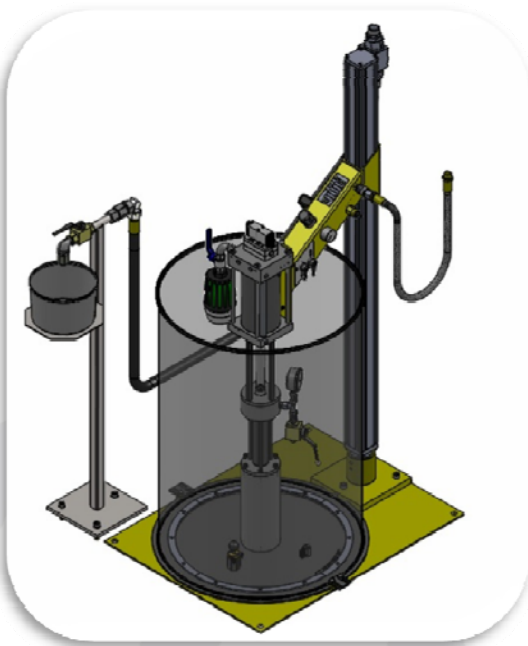

Ink dispensing table optionally with ball valve or pneumatically driven push button.



Betz ColorPump Ink pumps



Standard pneumatic pumps for 200kg drums



High volume pneumatic pumps for 200kg drums

Betz Ink Supply Systems
for Sheet-fed presses



Betz ColorTrans ink supply
for Ink Dosing Systems BMS



Betz ColorTrans ink supply systems

Standard ink piping system along the printing units,
optionally with fixed or flexible ink sequence

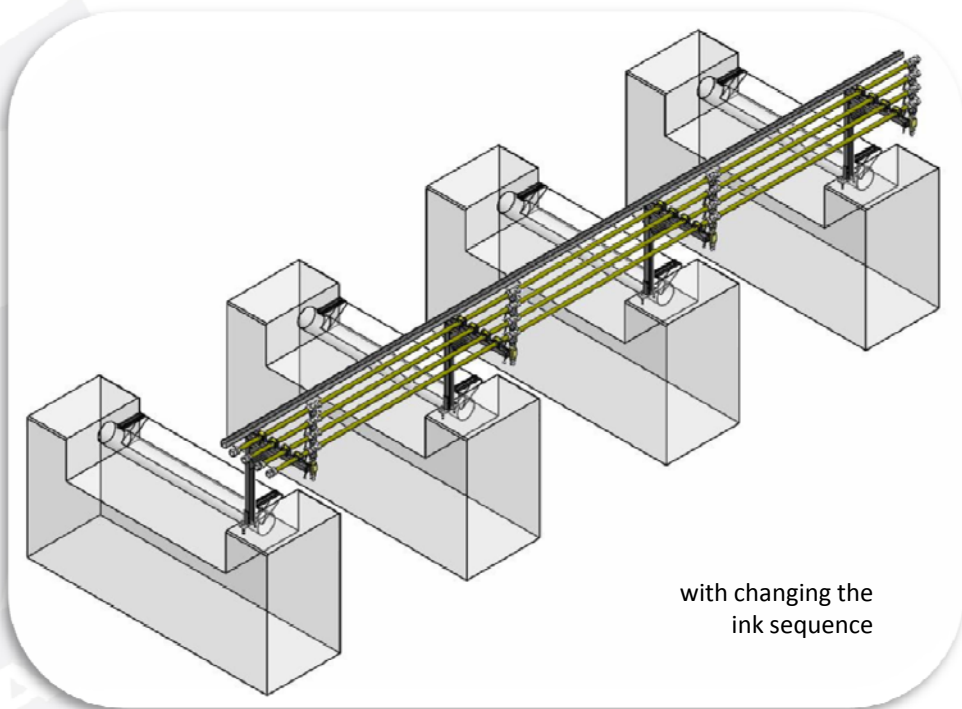
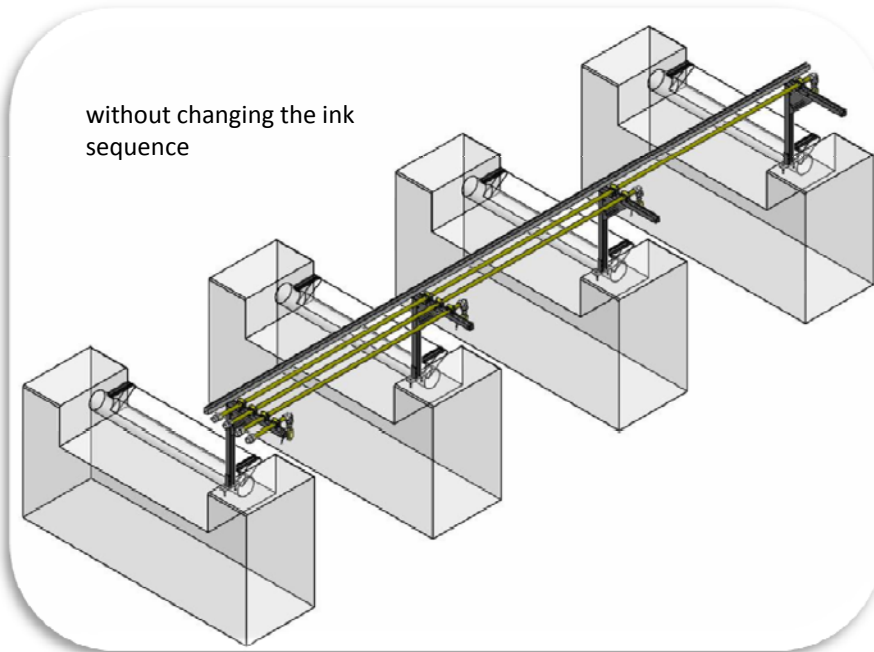

Betz ColorPro Ink Leveler BLS

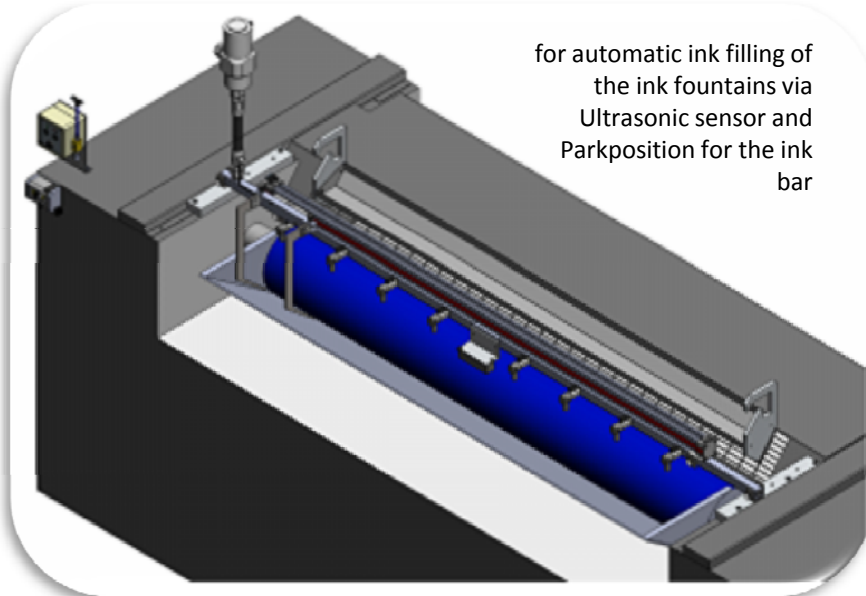

for automatic ink filling of
the ink fountains via
Ultrasonic sensor and
Parkposition for the ink
bar



for Semi-automatic filling
of the ink fountains
with pneumatic press-
button



for manual filling
of the ink fountain
through flexible
inkhose with ball-valve
(optional available with filling gun)



Betz ColorPro Ink Leveler BLS



- Quality
- Reliability
- Low- maintenance ...



... for you since more than 30 years!



Betz Ink Supply Systems
for Sheet-fed presses



Betz ColorPro Ink Leveler BLS



Ink pump Station
for 200 kg
Drums

Absolutely
reliable and now
installed in more
than 25,000
ink fountains
worldwide

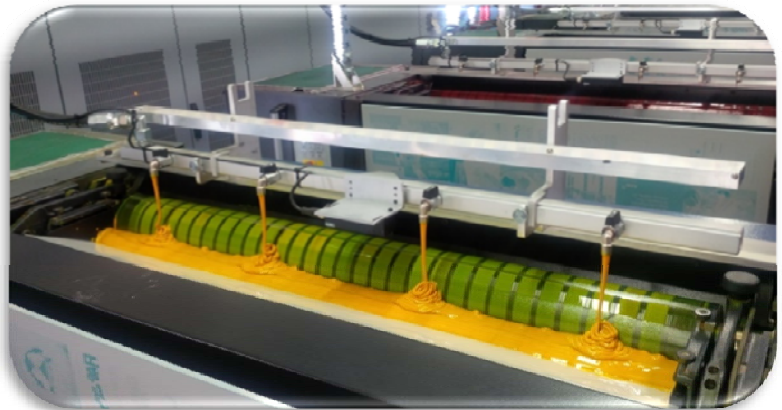

Automatic Ink
fountain filling
Via Betz BLS-System



Betz ColorPro Ink levellers BLS

Ink leveler bar in park position



Ink leveler in filling position

Betz ColorTrans equipment



Ink filters installed in the pipework prevent ingress of dirt particles through the ink into the press

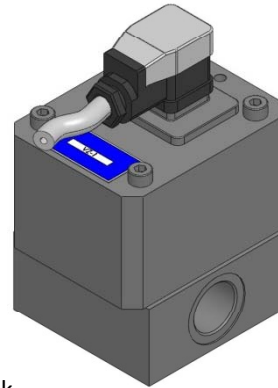

Ink Consumption System for order related ink consumption recording, visualization and analysis

Ink pipework in various sizes for connection between the pumpstation and the press



Betz ColorPress BCP 2,5kg Ink can dispensing system



BCP with ink adaptor
for connection to a
pump station

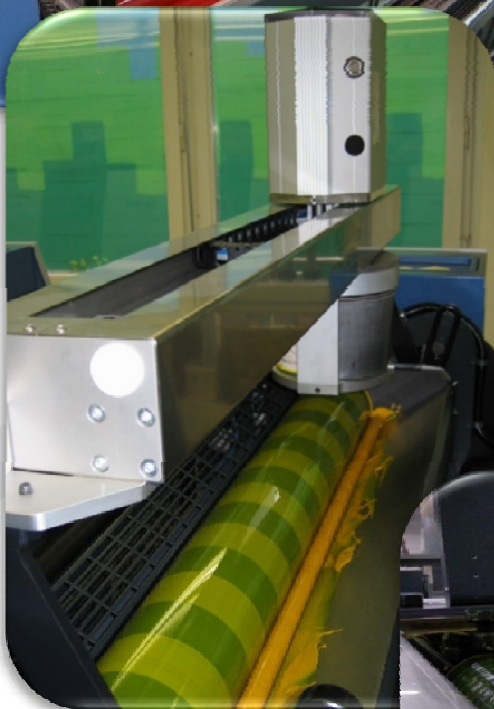

Automatic ink
filling of the ink
fountains out of
standard 2,5kg
cans. Version
for UV plastic
cans is also
available.

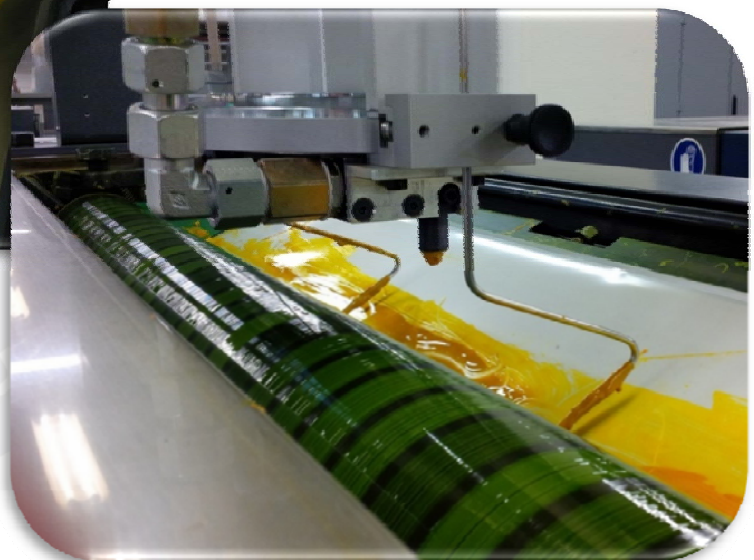

... ROI in shortest time
that allows your
business to be even
more effective

Betz ColorPress BCP 2,5kg Ink can dispensing system

BCP with ABB-control station connection



BCP for Plastic can for UV

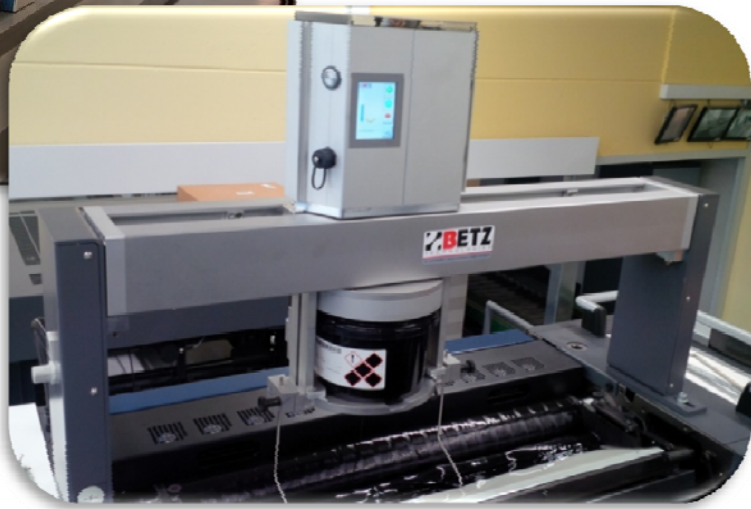

Punch device for metal can



BCP with in agitator for UV



Melting punch device for plastic cans

Betz ColorMove BIA Ink agitator

For continuous ink agitating in the ink fountais specially when using UV- resp. high viscosity inks

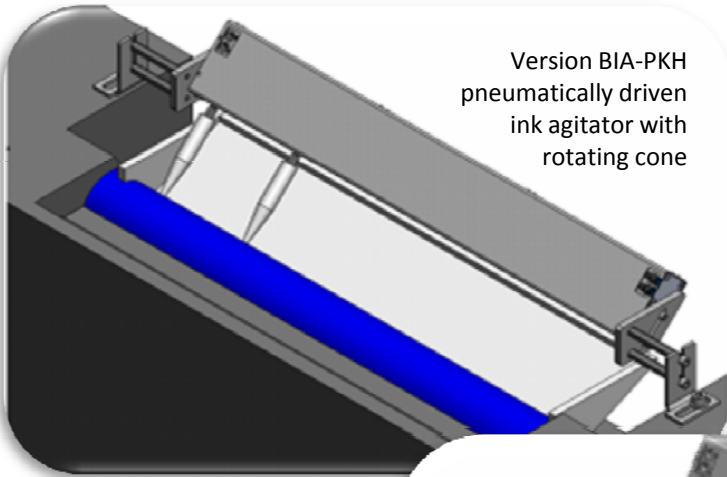

Version BIA-PKH
pneumatically driven
ink agitator with
rotating cone

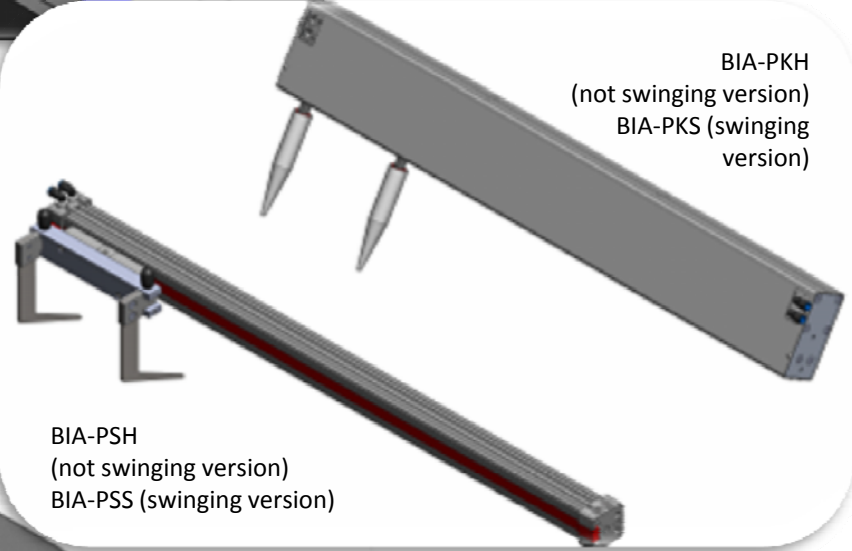

BIA-PKH
(not swinging version)
BIA-PKS (swinging
version)

BIA-PSH
(not swinging version)
BIA-PSS (swinging version)

Version BIA-PSH
pneumatically
driven ink agitator
with double scraper blade

Betz ColorMove BIA Ink agitator

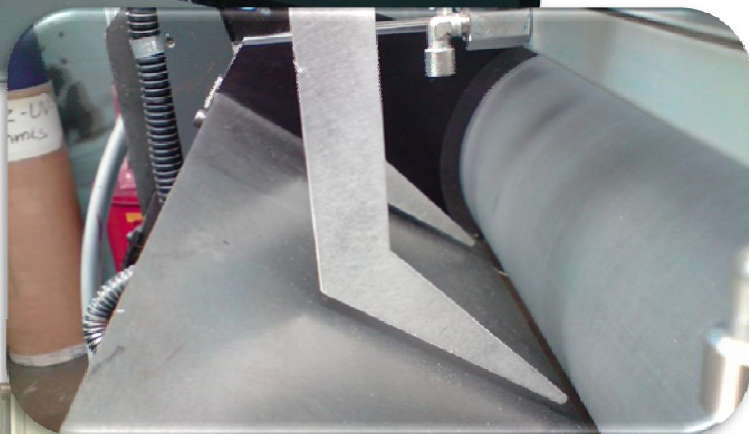

Ink agitator BIA-PSH
with double scraper
blade



Betz ColorMove BIA Ink agitator

Pneumatically driven ink agitator BIA
in connection with Ink can dispensing system BCP



Pneumatically driven ink agitator BIA
in connection with Ink leveller BLS

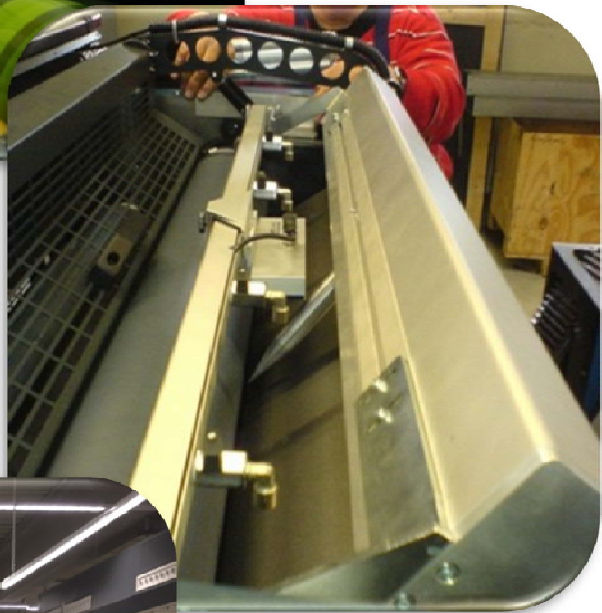

Pneumatically driven ink
agitator BIA
with rotating cone

Betz ColorGuard Ink fountain cover guard

Especially for sensitive LED-UV inks applications BETZ offers a ink fountain cover guard with integrated UV protection glass

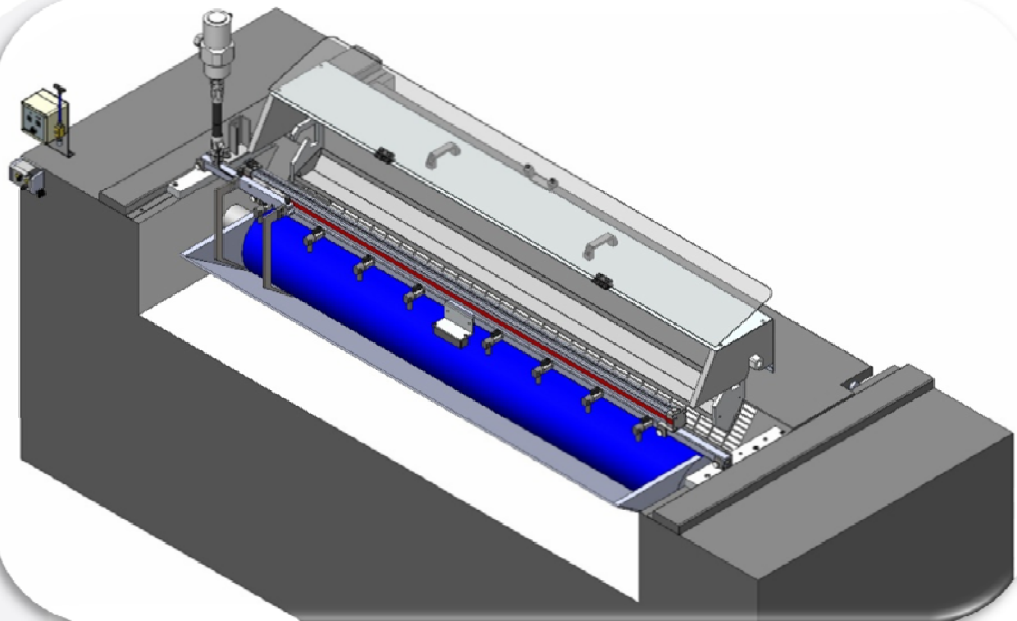
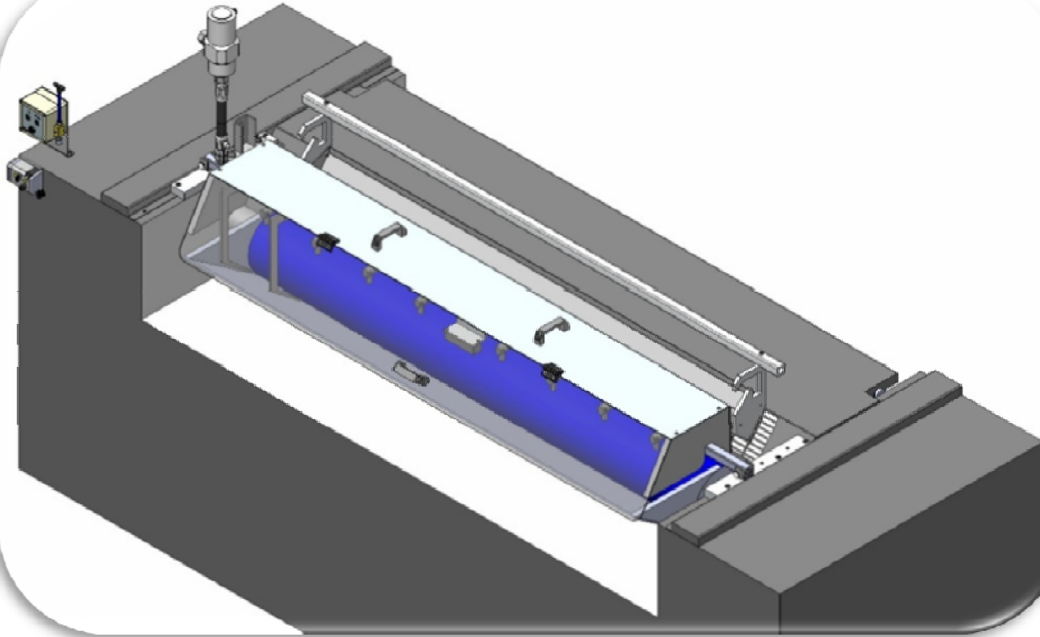

Betz Ink Supply Systems
for Sheet-fed presses



Complete installations, maintenance and repair work by our experienced service and assembly team



Betz Flow GmbH
Am Obereicholz 4
97828 Marktheidenfeld
Germany

Phone: +49 (0) 9391 98 26 – 0
Fax: +49 (0) 9391 98 26 – 50
info@betz.de
www.betz.de

