

BETZ ColorTrans

Ink supply systems

for Sheet-fed-presses

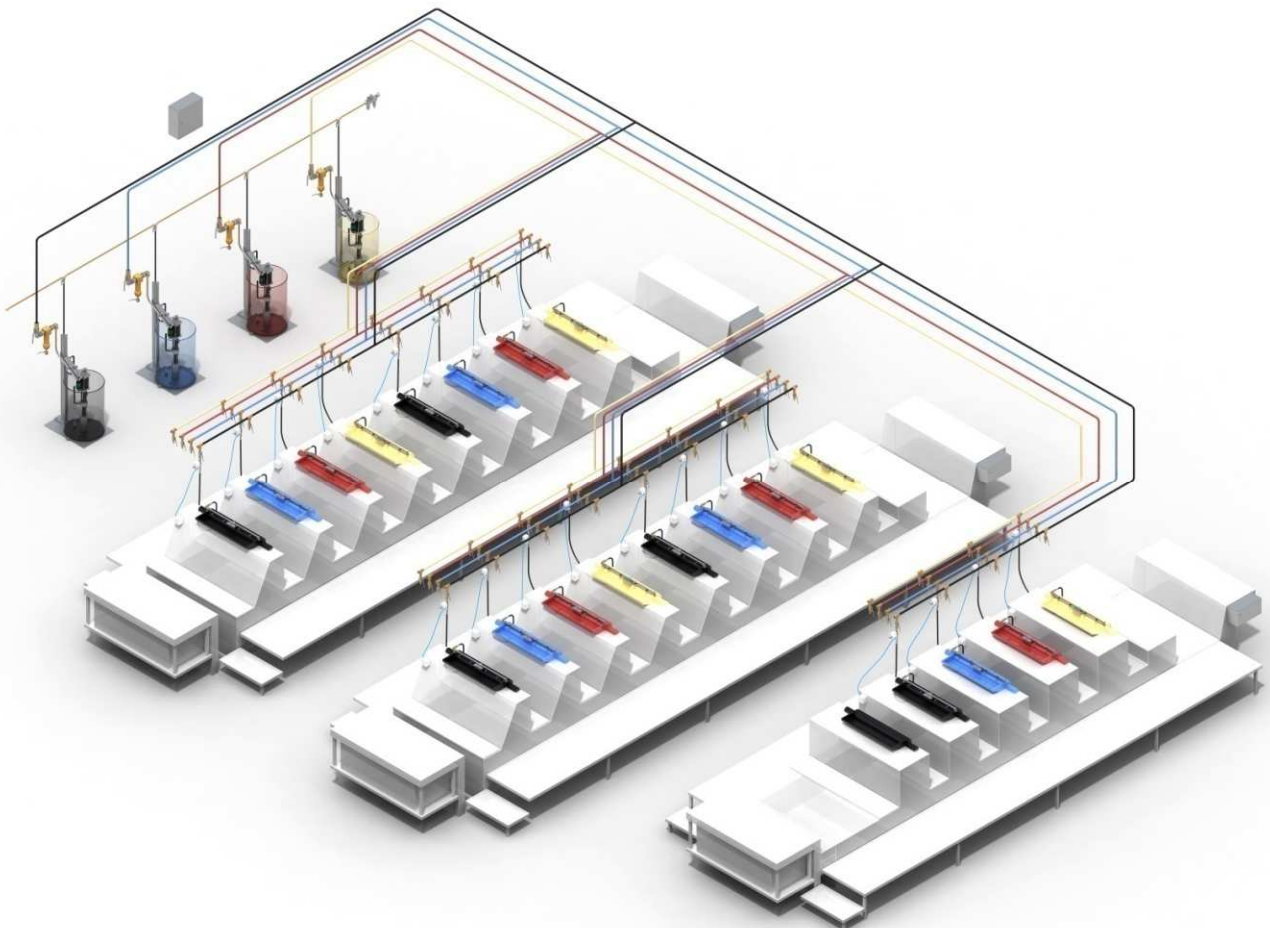

Betz ColorPump Ink pumps

Depending on the performance of your presses we have the right ink pump

Pail can pump P100/113-25H
Delivery/double stroke 113 cm³
Pressure ratio 21 : 1

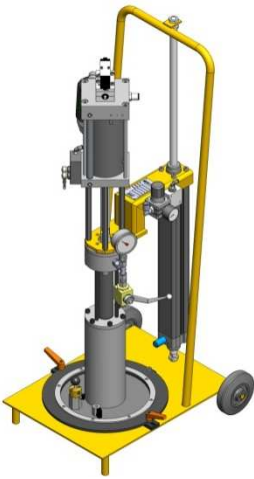

Drum pump P100/113-2L
Delivery/double stroke 113 cm³
Pressure ratio 21 : 1

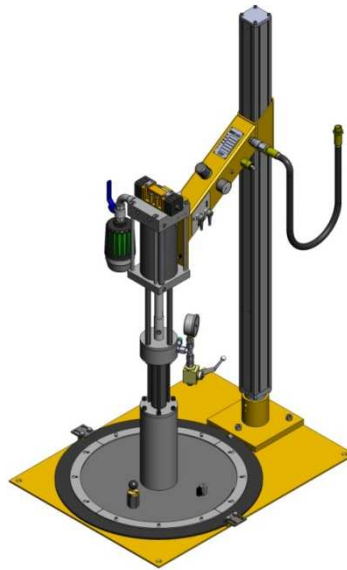

Drum pump P200/329-2L
Delivery/double stroke 329 cm³
Pressure ratio 30 : 1

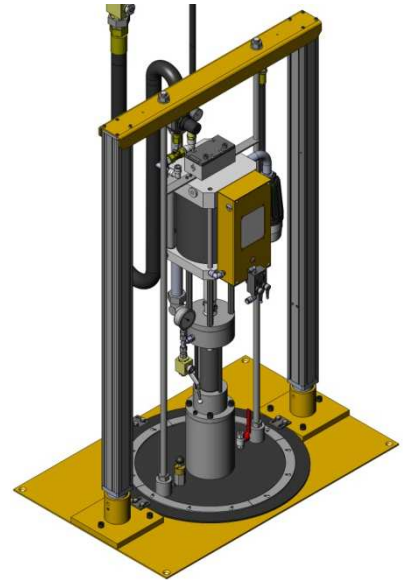

Drum pump P200/329-2L/DH
Delivery/double stroke 329 cm³
Pressure ratio 30 : 1



Drum pump P100/150-2/L/UV
Delivery/double stroke 150 cm³
Pressure ratio 8 : 1

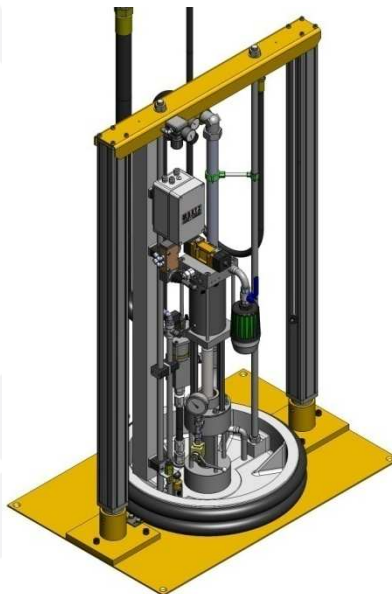

Pail can pump P100/150-25H/L/UV
Delivery/double stroke 113 cm³
Pressure ratio 8 : 1

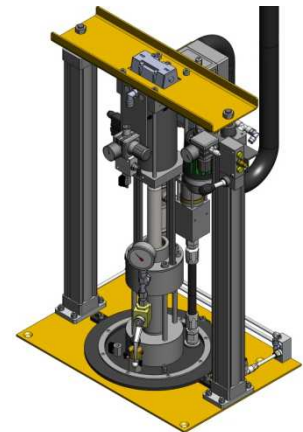

Betz ColorTrans ink supply

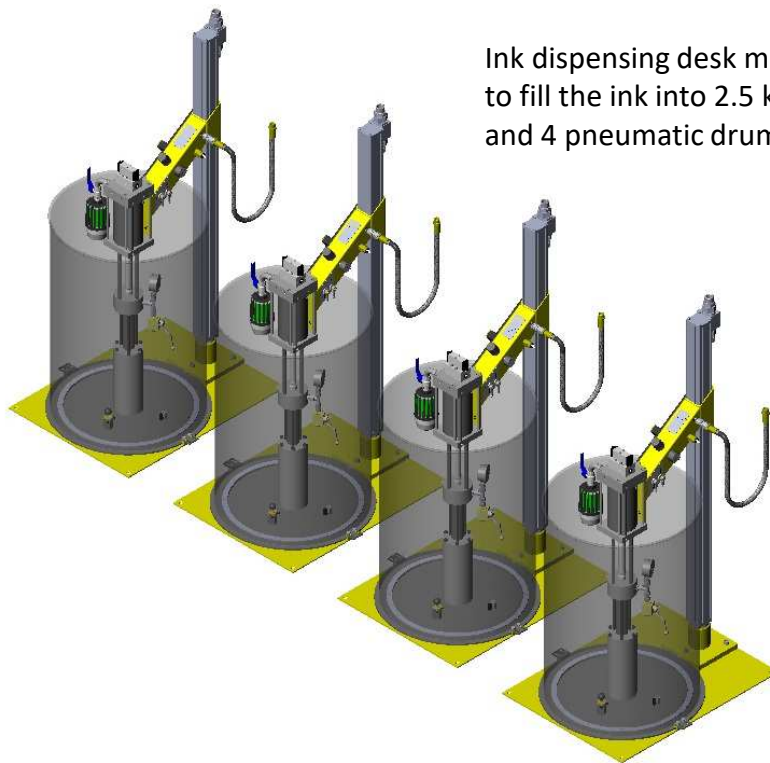

Ink dispensing desk made of stainless steel to fill the ink into 2.5 kg ink cans with pipe work and 4 pneumatic drum pumps.

Ink dispensing table optionally with ball valve or pneumatically driven push button.

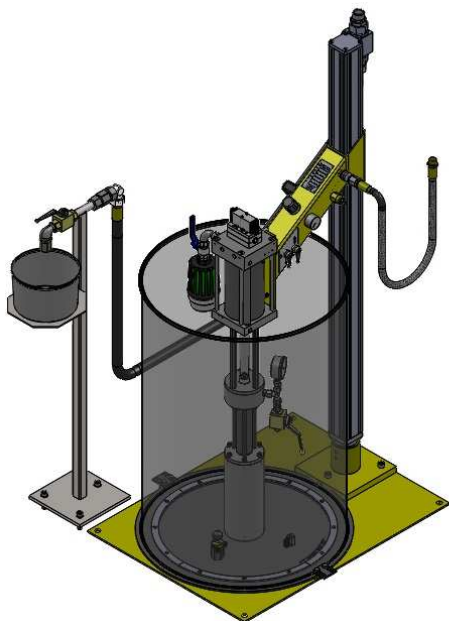

Single Ink dispensing stand for 2.5 kg cans manual

Betz ColorPump Ink pumps

Standard pneumatic pumps for 200kg drums



High volume pneumatic pumps for 200kg drums



**Betz ColorTrans ink supply
for Ink Dosing Systems BMS**



Betz ColorTrans ink supply systems

Standard ink piping system along the printing units,
optionally with fixed or flexible ink sequence

without changing the ink
sequence

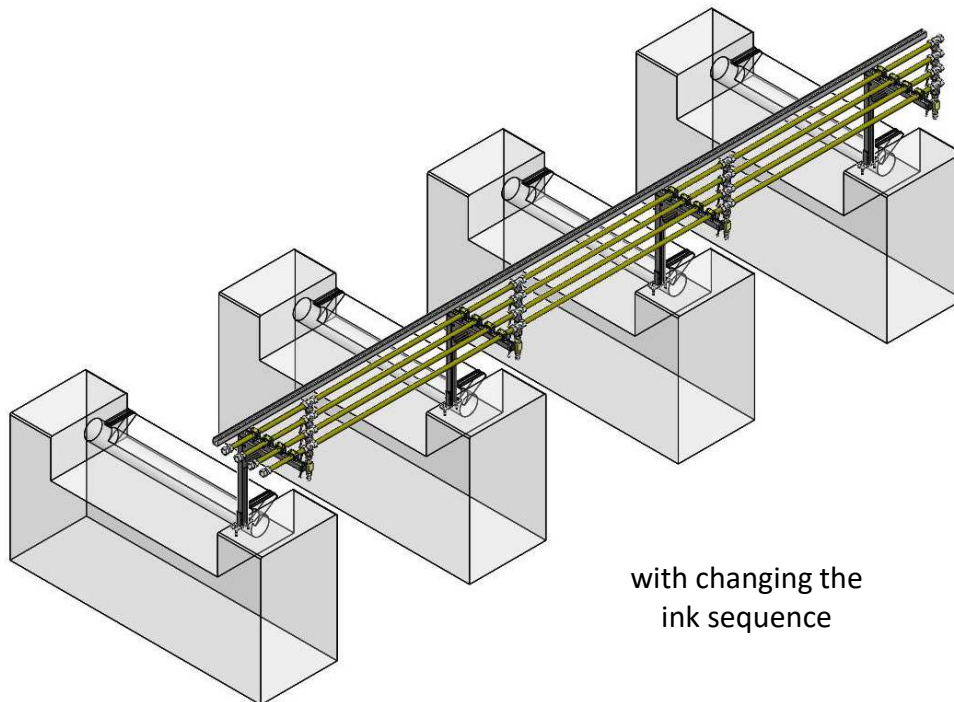
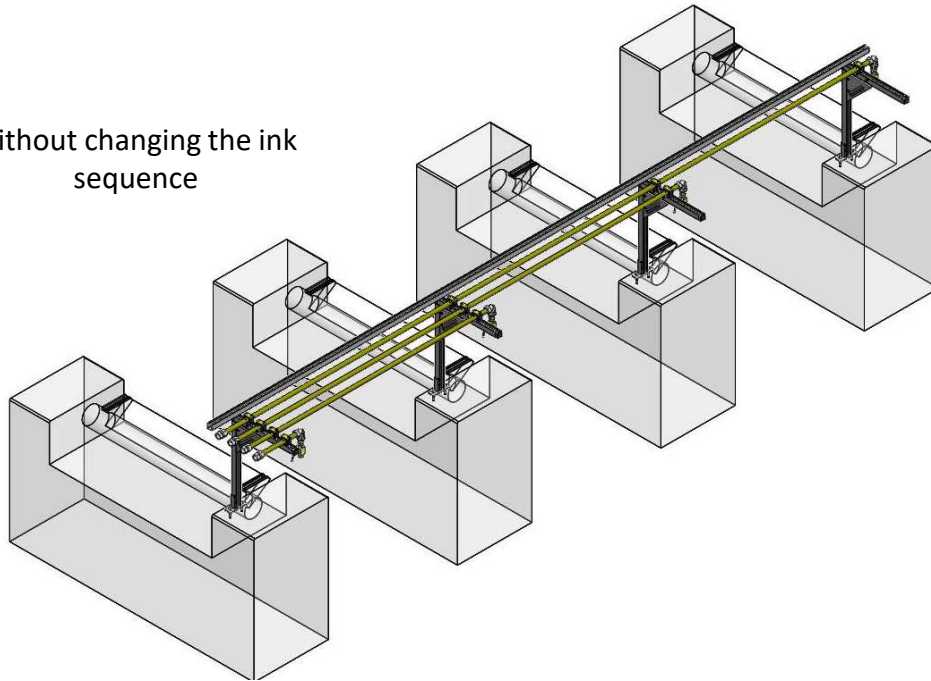

with changing the
ink sequence

Betz ColorPro Ink Leveler BLS

for automatic ink filling of the ink fountains via Ultrasonic sensor and Parkposition for the ink bar

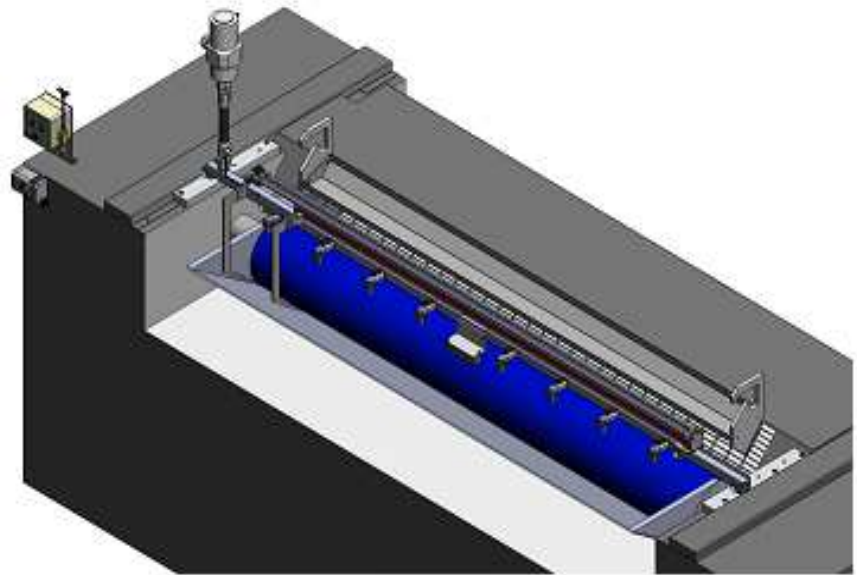

for Semi-automatic filling of the ink fountains with pneumatic press-button

for manual filling of the ink fountain through flexible inkhose with ball-valve (optional available with filling gun)



Automatic Ink Leveller BLS and Ink Agitator BIA for Sheet fed with park position for the ink bar

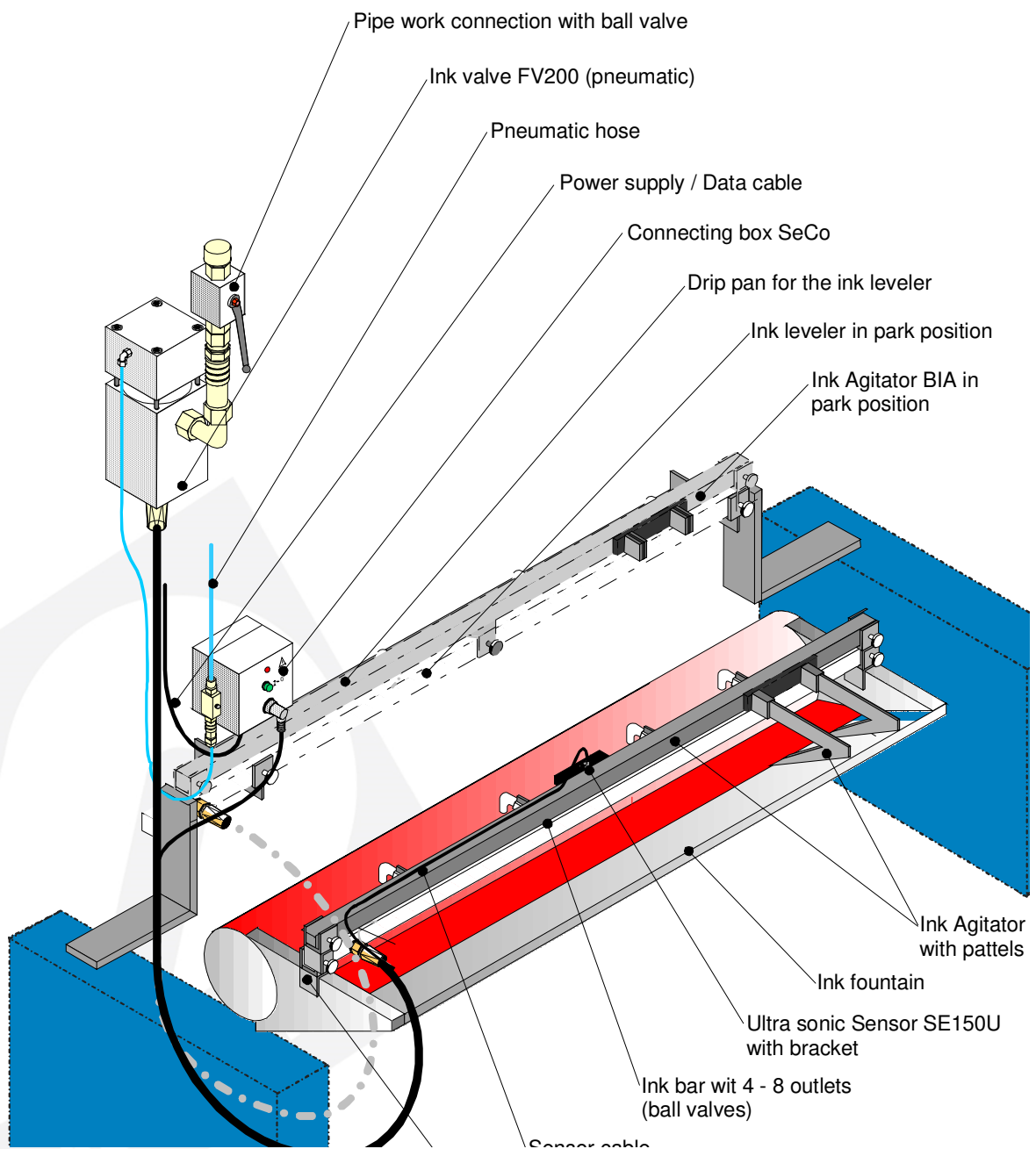

Betz ColorPro Ink Leveler BLS

- Quality
- Reliability
- Low- maintenance ...

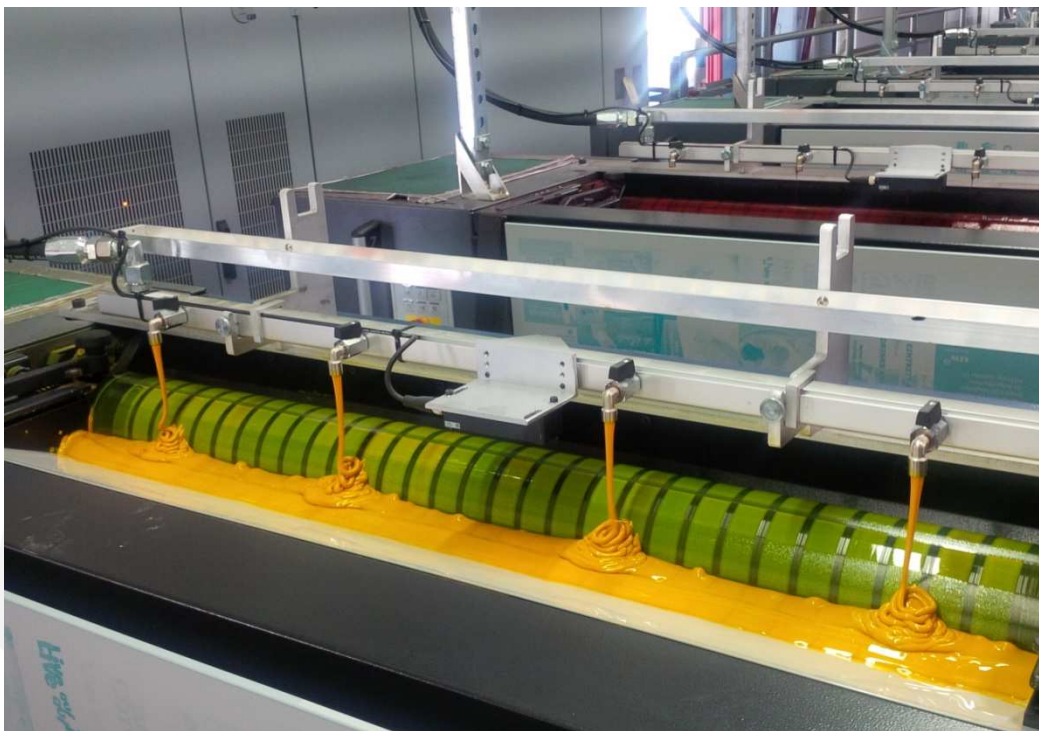

... for you since
over 30 years!



Betz ColorPro Ink Leveler BLS



Ink pump Station
for 200 kg Drums

Absolutely reliable and now
installed in more than 25,000
ink fountains worldwide

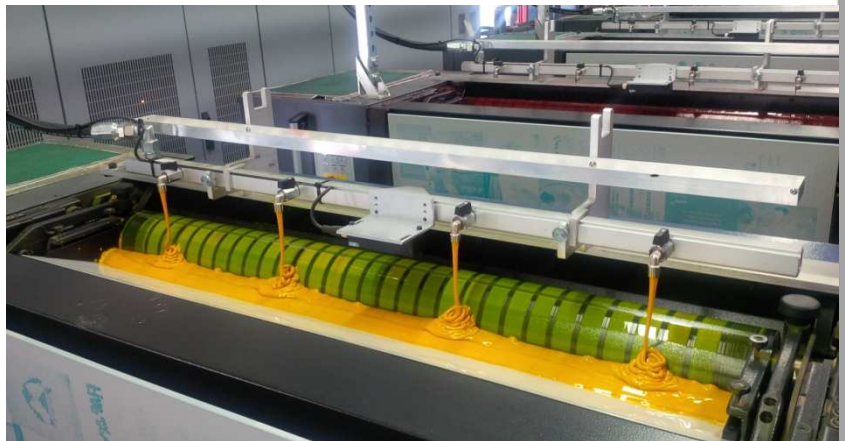

Automatic Ink fountain filling
Via Betz BLS-System



Betz ColorPro Ink levellers BLS

Ink leveler bar
with park position



Ink leveler in filling
position

Betz ColorTrans equipment

Ink filters installed in the pipework prevent ingress of dirt particles through the ink into the press

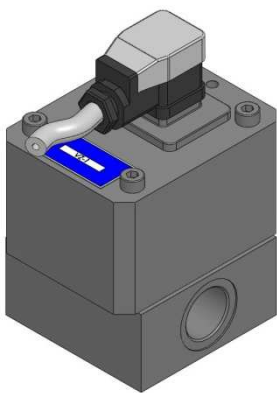

Ink consumption control system
For order-related ink consumption
recording, visualization and analysis

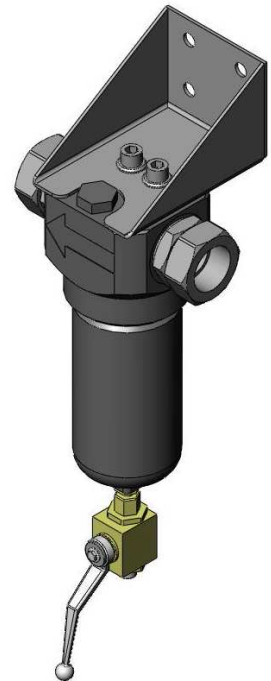

Manually Ink Ink filling system



Betz ColorTrans UV – Ink pumps

Ink pumps available for every field of application manufactured in the well-known Betz quality since nearly 35 years

200kg Drum pump P100/150-2L/L/UV/DH/20/V2
Delivery rate / cycle 154 cm³
Pressure ratio 8 : 1

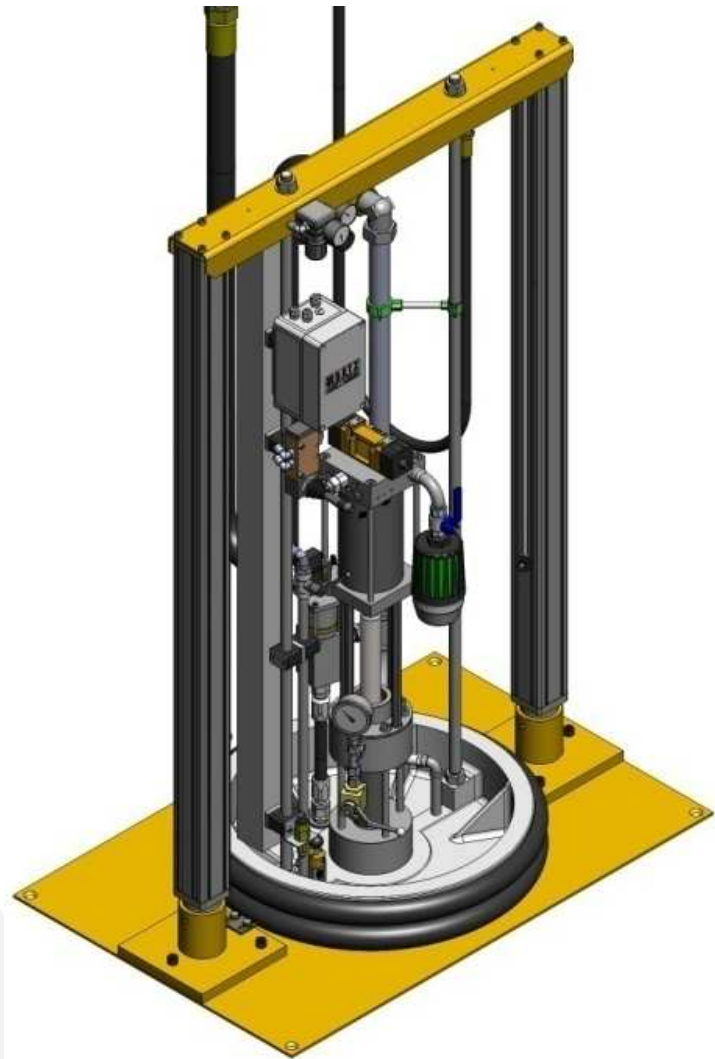

Pail can pump P100/150-25H/L/UV/DH
Delivery/double stroke 154 cm³
Pressure ratio 8 : 1

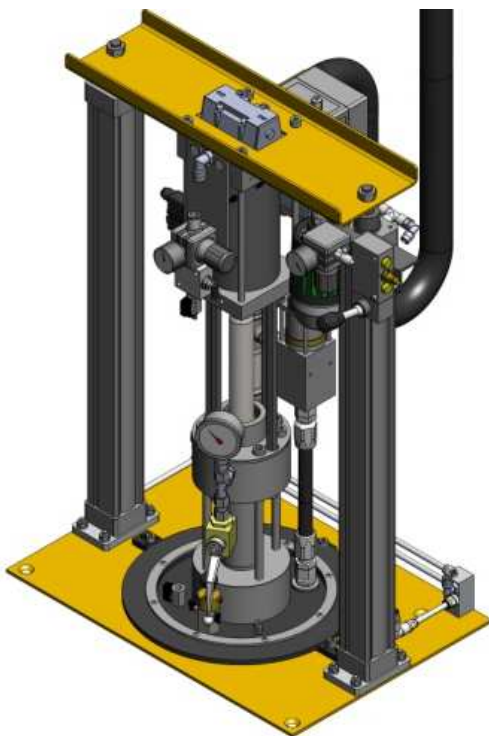

Betz ColorPump UV ink pumps

Betz ink pumps as standard for the UV offset ink field out of 200 kg ink drums and 25 kg pail cans, offers a high, user-friendly operation.



Betz ColorMove BIA UV – Ink Agitator for Sheet fed presses

Betz Technologies has the most and longest experience in this market segment with world wide Installations.

Customers in Australia, Belgium, Germany, Finland, France, Italy, Japan, Malta, Netherlands, Poland, Russia, Saudi Arabia, Sweden and Turkey already rely on our technique.



Special component parts for the UV pumps permit a failure-free operation in the field of newspaper, commercial web and sheet-fed offset.

Betz ColorPress BCP 2,5kg Ink can dispensing system



BCP with ink adaptor for connection to a pump station

Automatic ink filling of the ink fountains out of standard 2,5kg cans. Version for UV plastic cans is also available.

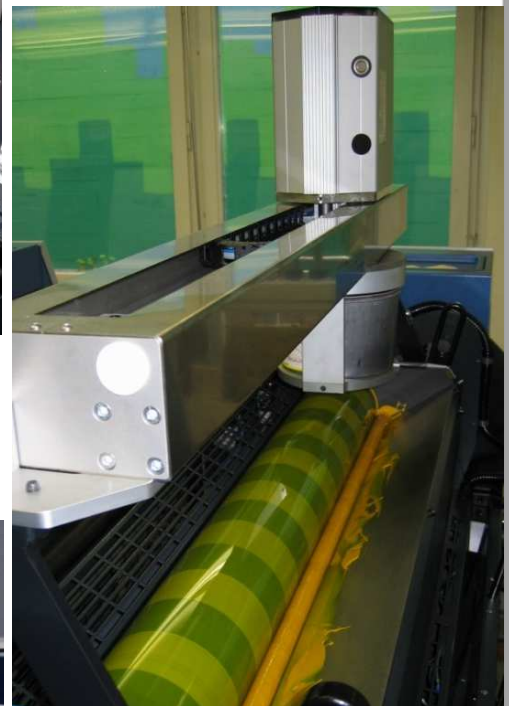

... ROI in shortest time that allows your business to be even more effective

BETZ Dosing System BMS for UV-Ink!



Betz UV - Pumps for Dosing Systems BMS



Betz ColorPress BCP 2,5kg Ink can dispensing system

BCP in connection with Ink Pump system



BCP with ABB-control station connection



Punch device for metal can



BCP with in agitator for UV

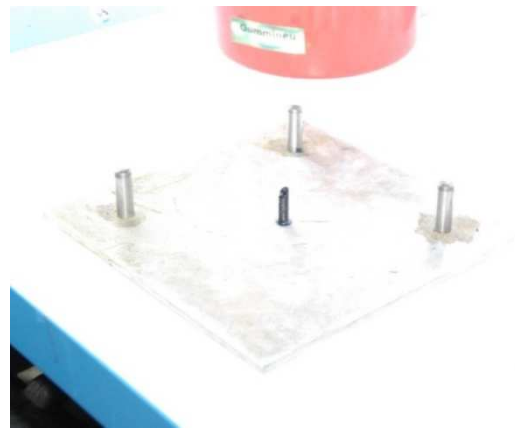

Melting punch device for plastic cans

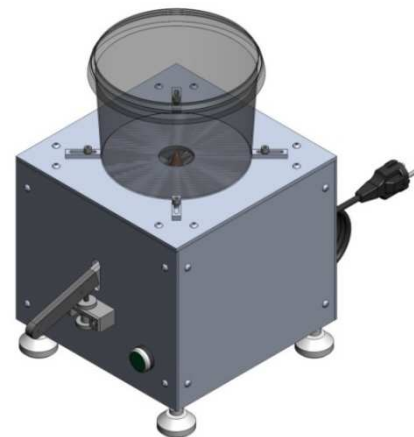

Betz ColorMove BIA Ink agitator

For continuous ink agitating in the ink fountais specially when using
UV- resp. high viscosity inks

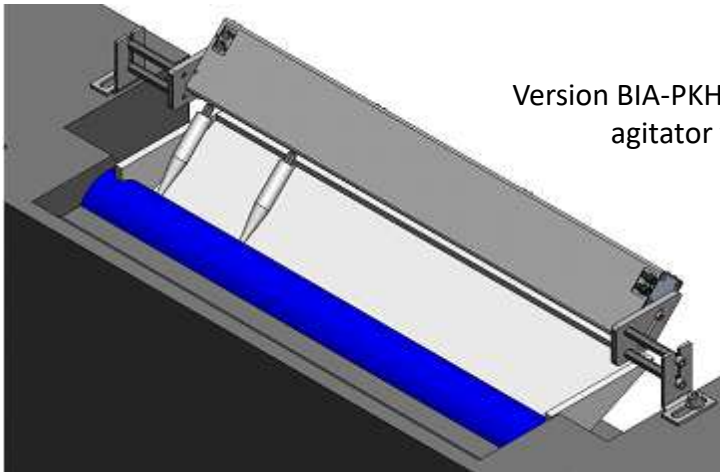

Version BIA-PKH pneumatically driven ink
agitator with rotating cone

BIA-PKH (not swinging version)
BIA-PKS (swinging version)

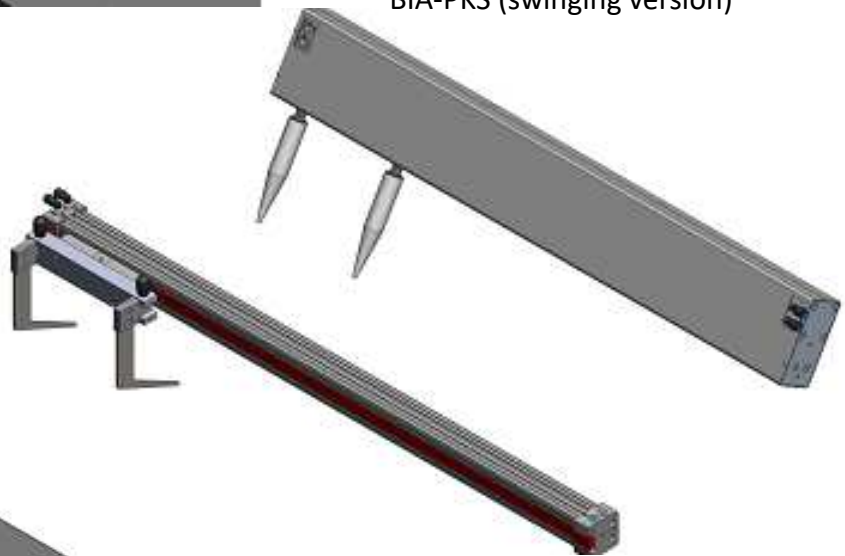

BIA-PSH (not swinging version)
BIA-PSS (swinging version)

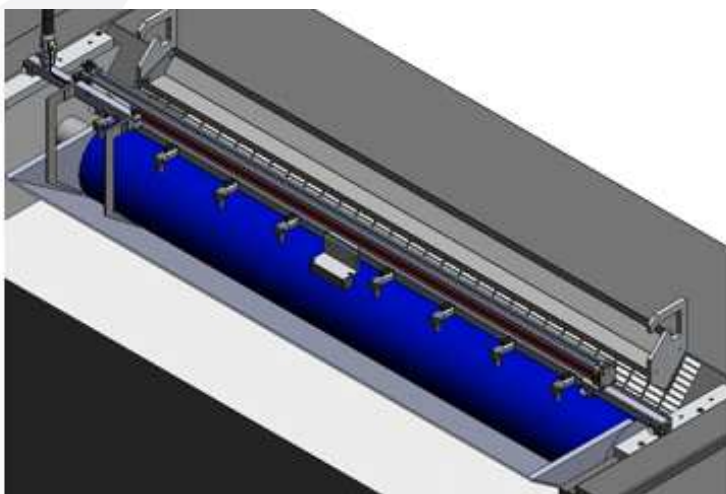

Version BIA-PSH pneumatically
driven ink agitator
with double scraper blade



Betz ColorMove BIA Ink agitator

Pneumatically driven ink agitator BIA in connection with dispensing system BCP out of plastic Ink can for UV-Ink



Pneumatically driven ink agitator BIA
in connection with Ink leveller BLS

Pneumatically driven ink agitator
BIA with rotating cone

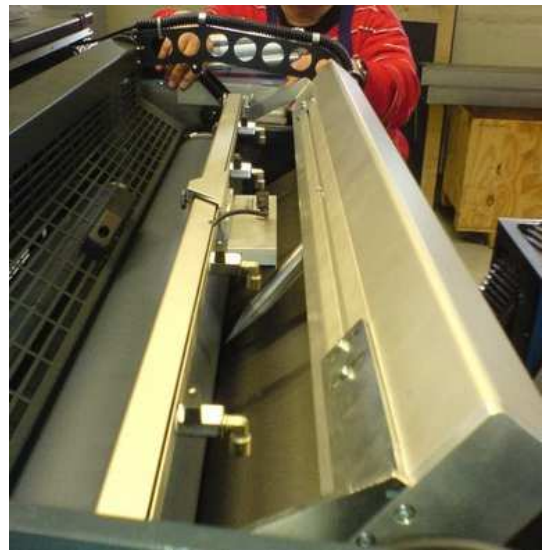

Betz ColorGuard Ink fountain cover guard

Especially for sensitive LED-UV inks applications BETZ offers a ink fountain cover guard with integrated UV protection glass

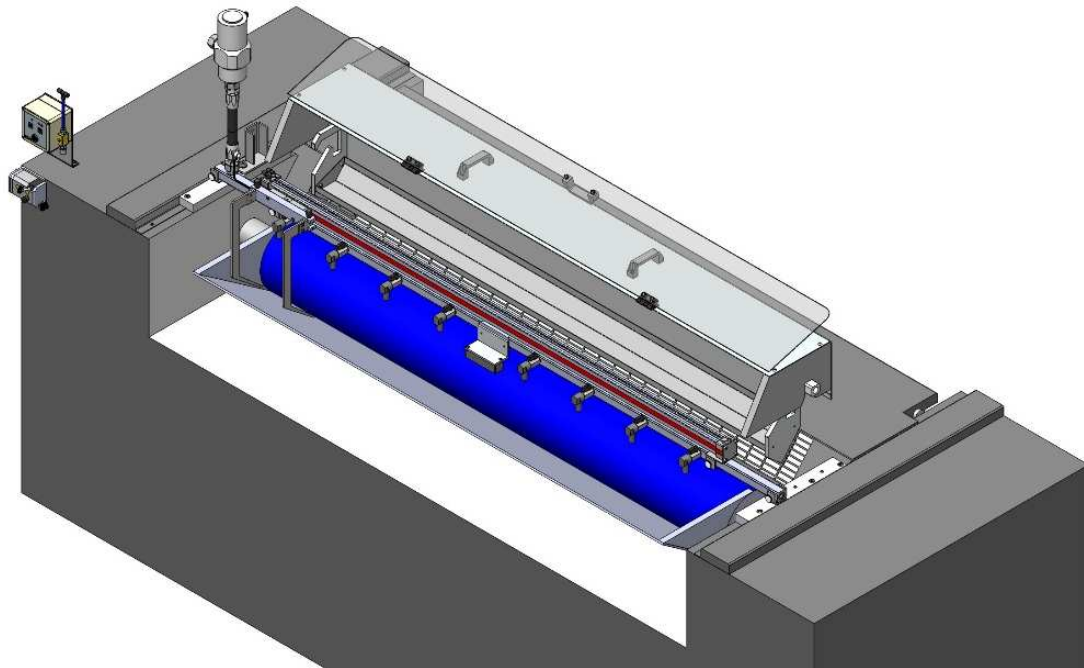
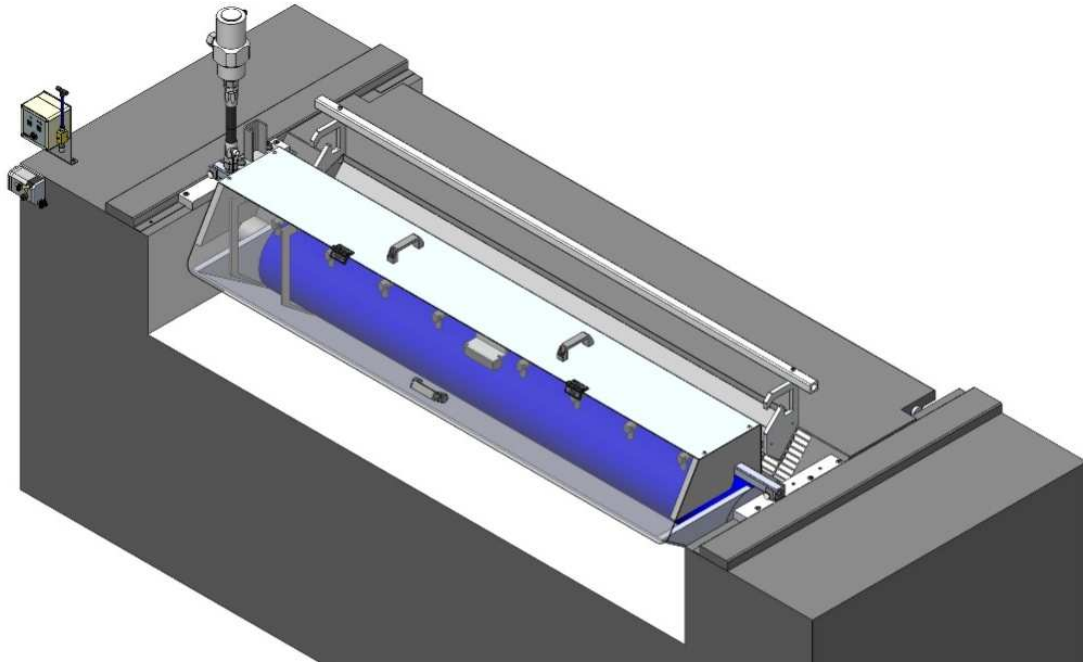

**Betz Ink Supply Systems
for Sheet-fed presses**



Complete installations, maintenance and repair work by our experienced service and assembly team



Betz Flow GmbH

Am Obereicholz 4
97828 Marktheidenfeld
Germany

Phone: +49 (0) 9391 98 26 – 0
Fax: +49 (0) 9391 98 26 – 50
info@betz.de
www.betz.de

