

# Betz ColorTrans Ink Supply Systems für Heat- und Coldoffset

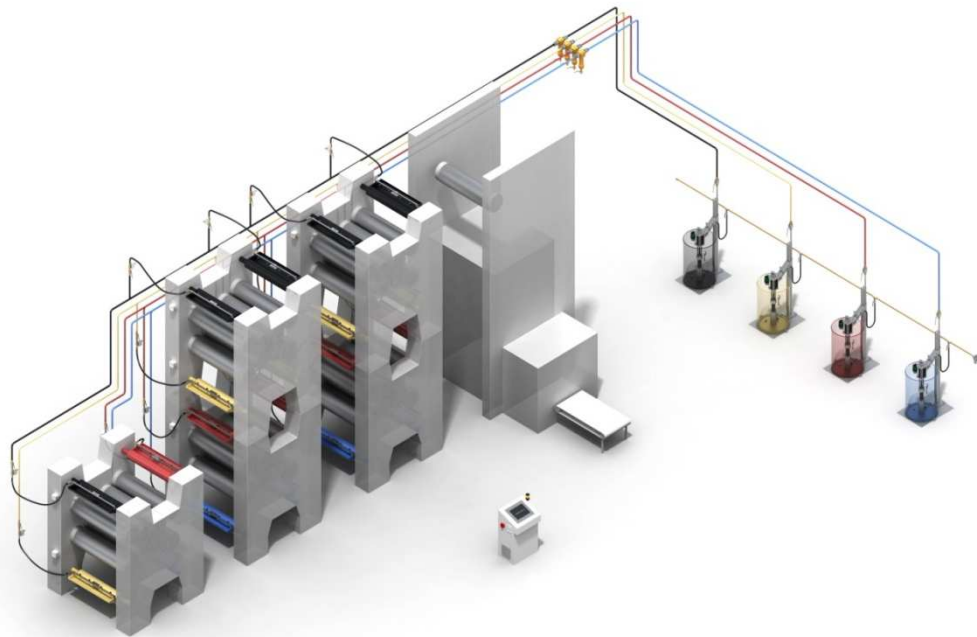
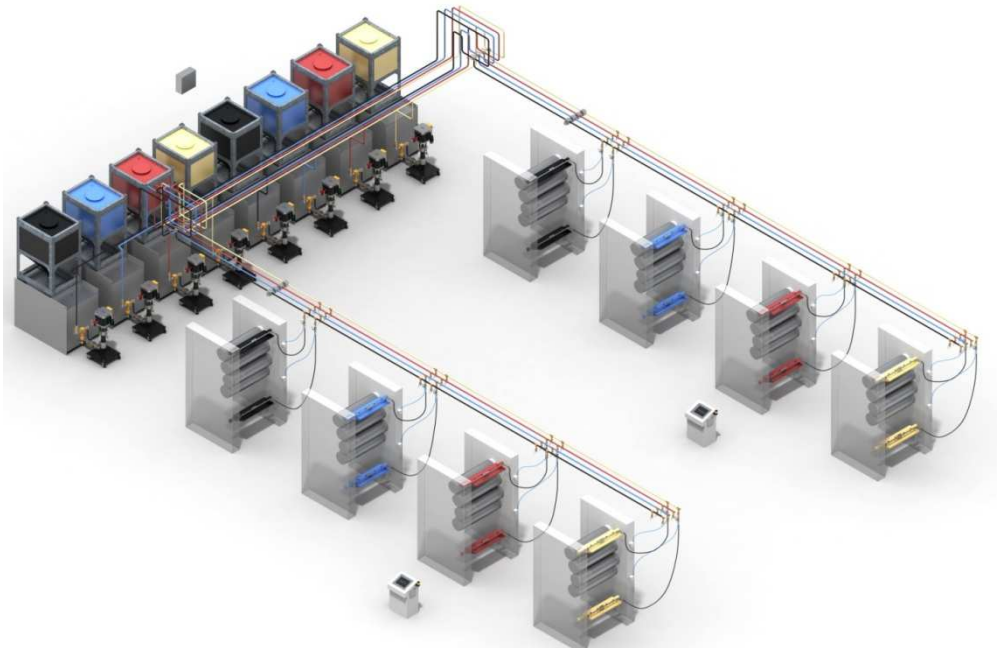

## Betz ColorTrans Ink Pumps

Ink pumps available for every field of application manufactured in the well-known Betz quality since nearly 35 years

**Containerpump P320/970-1/PLC**  
Delivery rate / cycle 970 cm<sup>3</sup>  
Pressure ratio 39 : 1

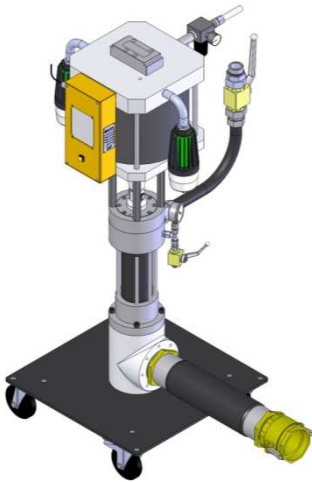

**Containerpump P250/656-1/PLC**  
Delivery rate / cycle 656 cm<sup>3</sup>  
Pressure ratio 23 : 1

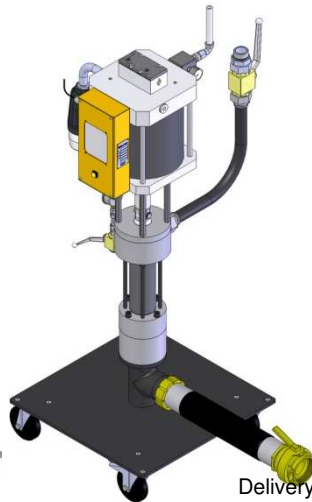

**Containerpump P200/3923-1/PLC**  
Delivery rate / cycle 329 cm<sup>3</sup>  
Pressure ratio 30 : 1



Delivery rate / cycle

**Containerpump 080/970/H**  
Delivery rate / cycle 970 cm<sup>3</sup>  
Pressure ratio 0,8 : 1



**200 kg Fasspump P200/329-2L**  
Delivery rate / cycle 329 cm<sup>3</sup>  
Pressure ratio 30 : 1

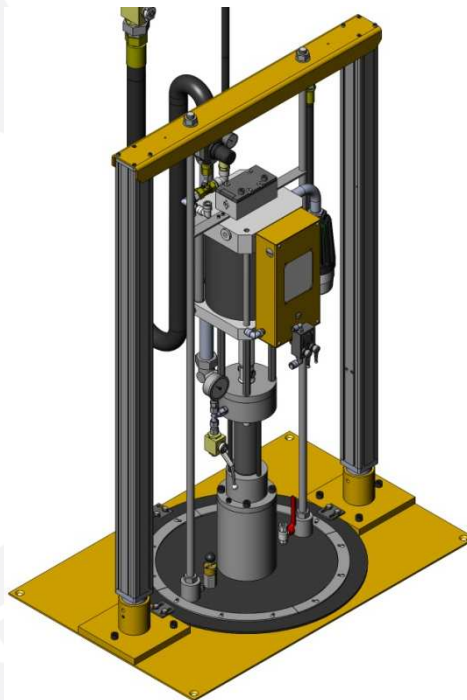

**200 kg Fasspump P100/113-2L**  
Delivery rate / cycle 113 cm<sup>3</sup>  
Pressure ratio 21 : 1

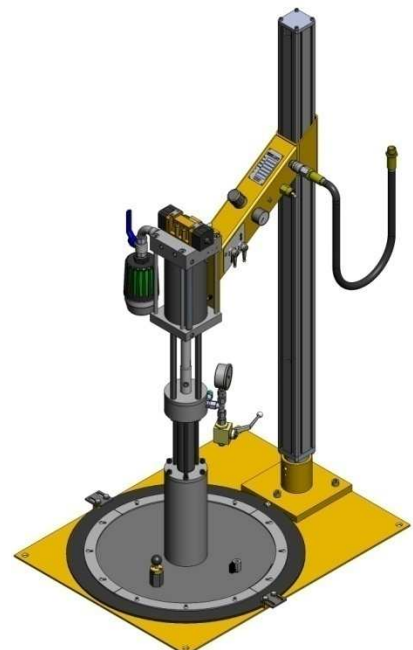

## Betz ColorTrans ink supply

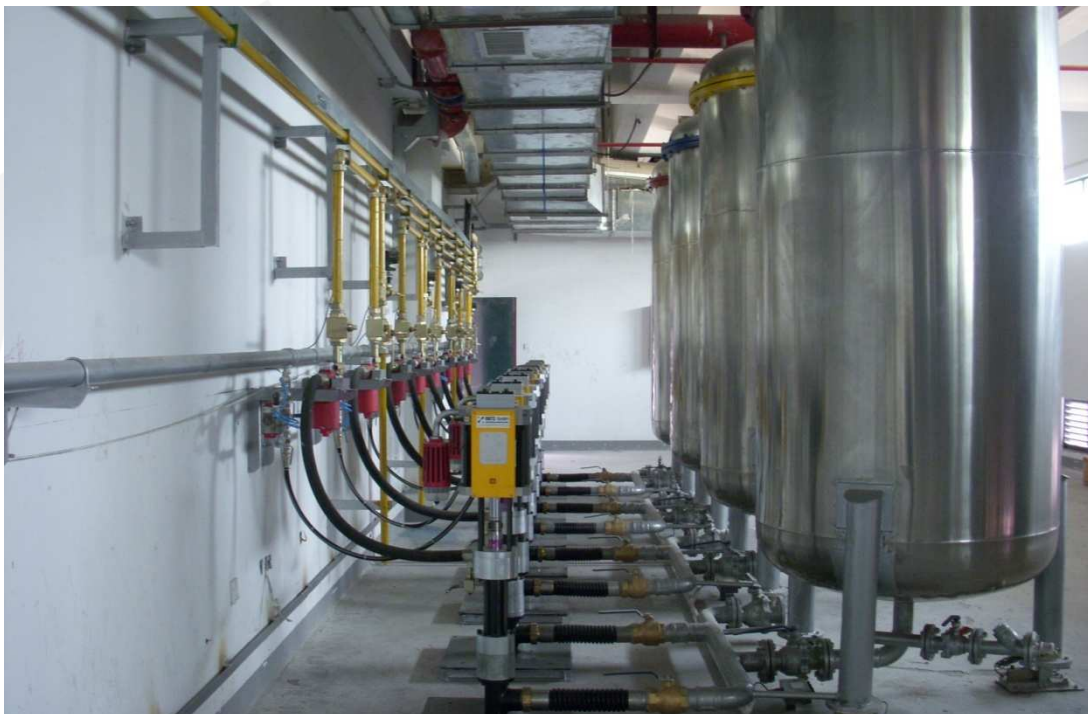

## Betz ColorTrans ink supply

Pump stations installed  
with 1500 kg Base container

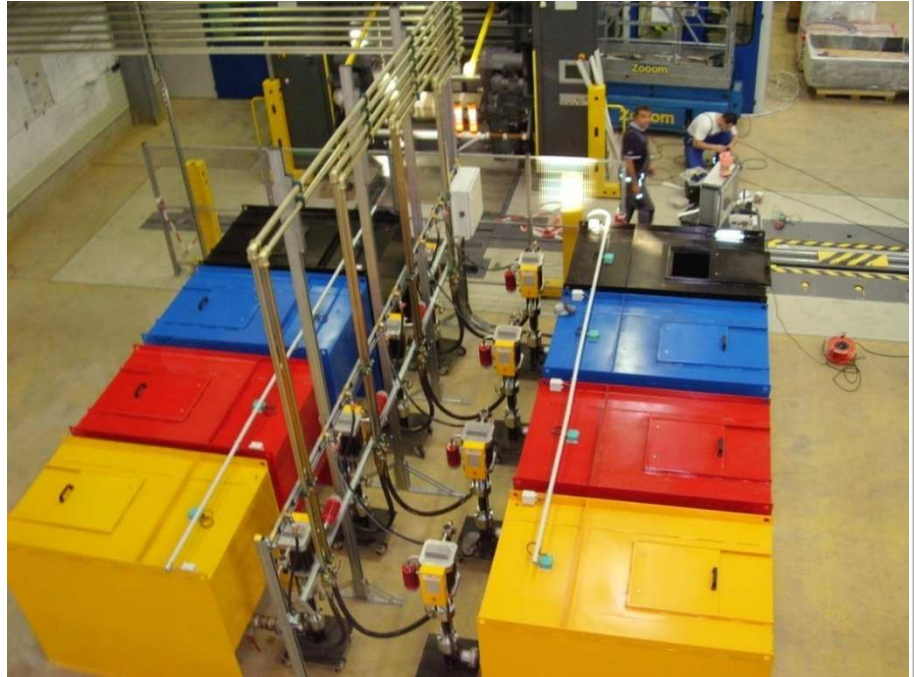

... or 200 kg drums

**Betz Ink Supply Systems  
for Sheet-fed presses**

Pump stations installed  
with 1500 kgBase container

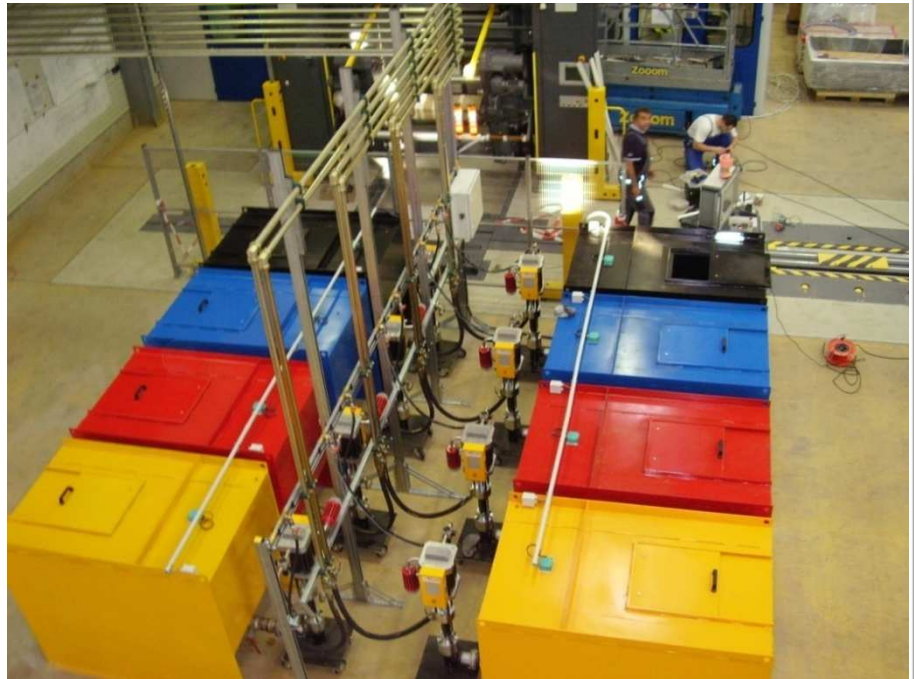

... or 200 kg drums



## Betz ColorTrans ink supply

Base container with 2.500 kg content to put 2 mobile container with 1.000 kg content on top, with the possibility for a test container connection

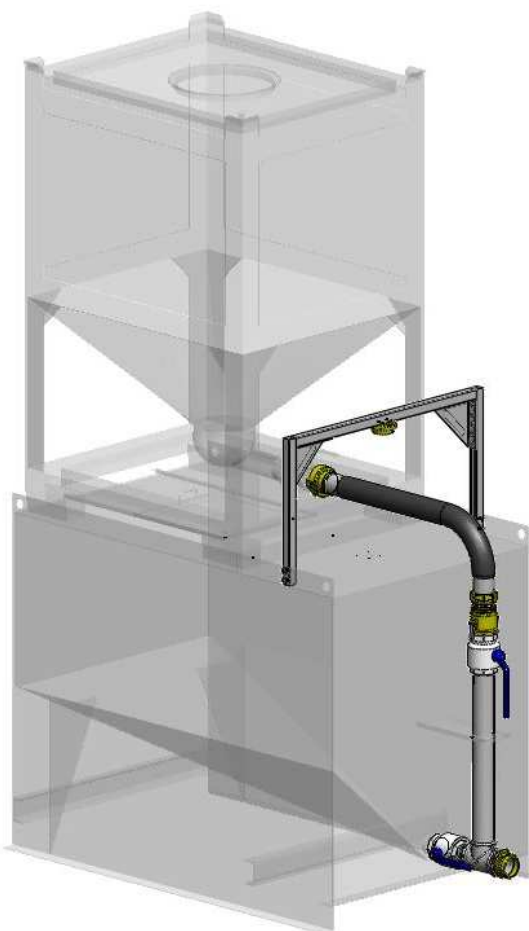

Base container with 1.500 kg content to put 1 mobile container 1.000 kg content on top with the possibility for a test container connection

## Betz ColorTrans ink supply

Ink consumption measurement integrated into the pipe work for order-related consumption recording with visualization and reporting via control terminal

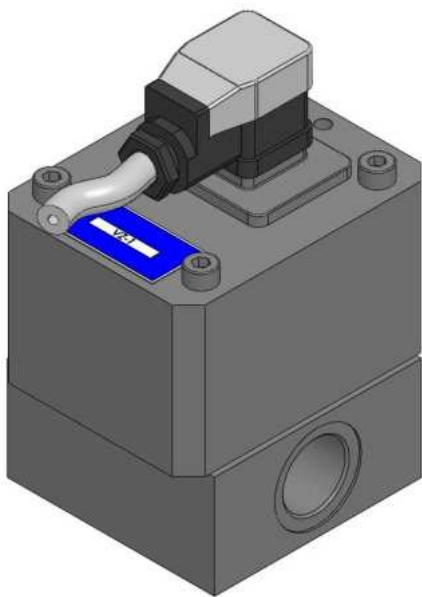

Ink filter installed into the pipe work to avoid dirt particles getting via the ink into the press

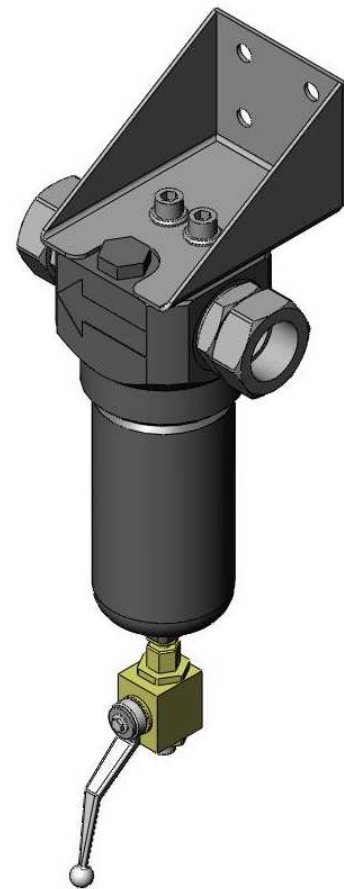

Pipe work systems in different dimensions as interface between the pumps and the presses

## Betz ColorPro Ink level control

Automatic ink fountain filling with ink level controller BLS

Installed at more than 25,000 ink fountains worldwide

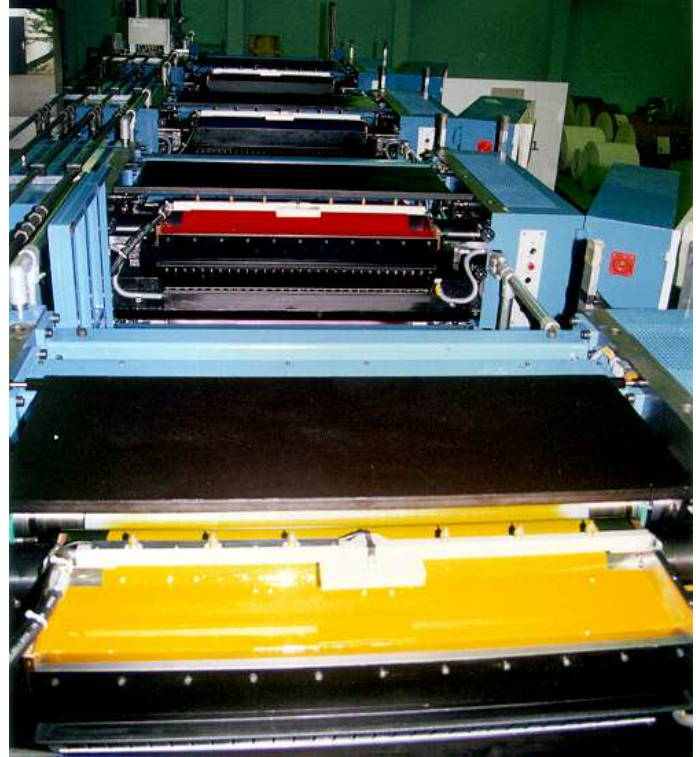



## Betz ColorPro Ink level control

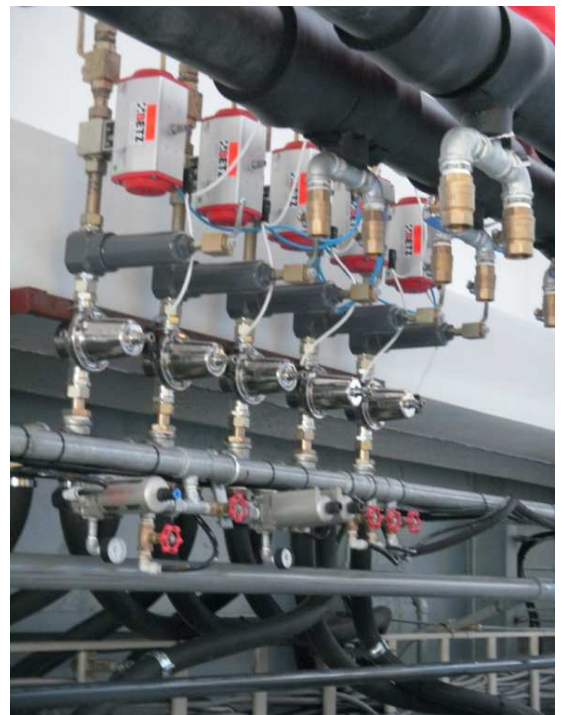

## Betz ColorPro Ink level control



**Betz Ink Supply Systems  
for Sheet-fed presses**



Ink tanks with Testcontainer connection



## Betz ColorTrans Ink Tanks

Suitable ink pumps with the necessary delivery volume  
available in different designs - pneumatically or hydraulically driven

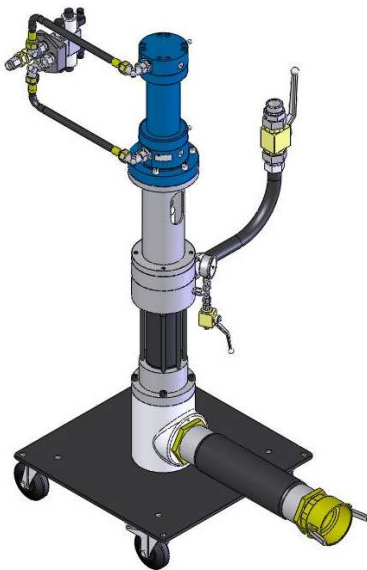
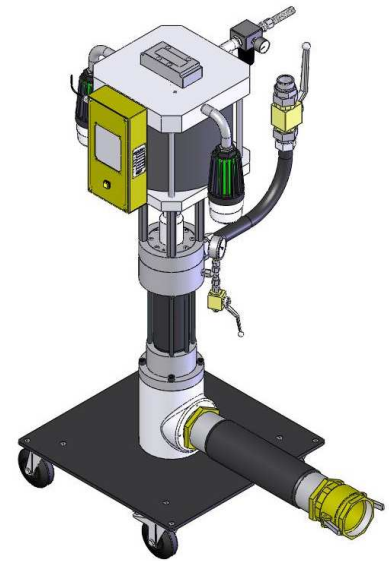

**Betz Ink Supply Systems**  
for Sheet-fed presses

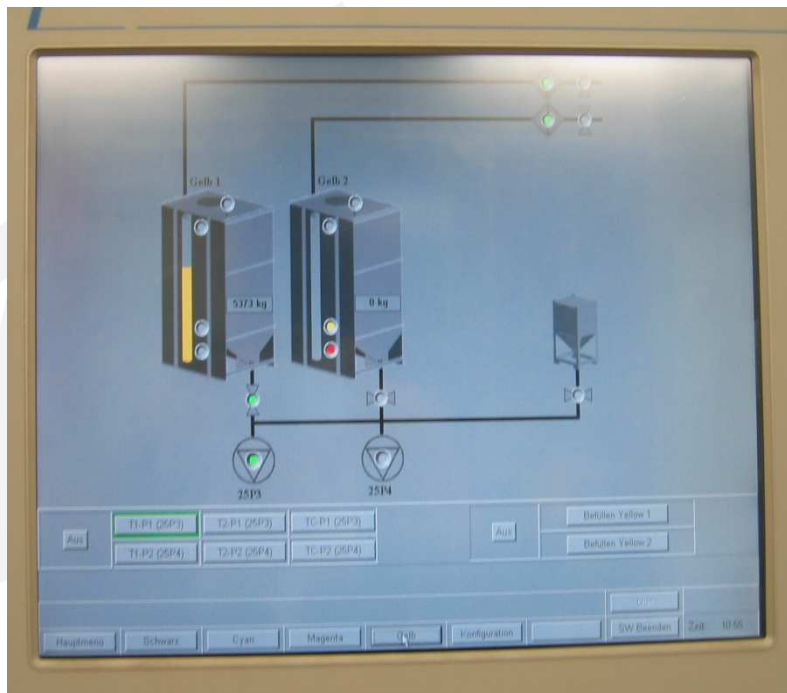
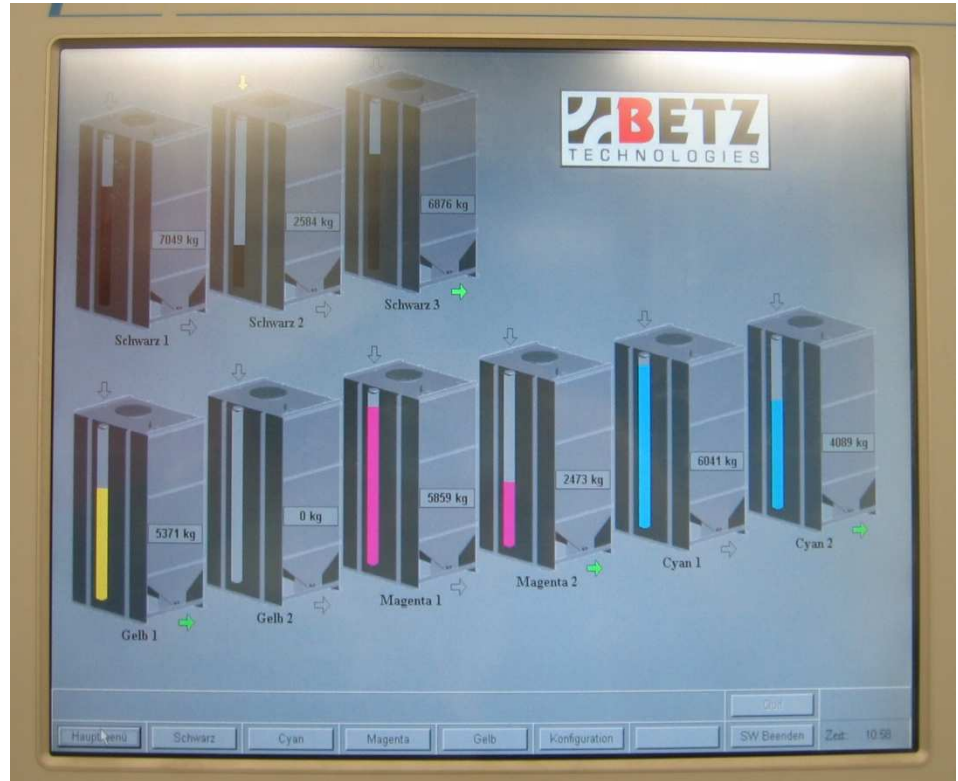

## Betz ColorRest Ink left over recycling RSA

Automatic Ink left over recycling system RSA-R for Web-Offset



Semi-Automatic Ink left over recycling system RSA-Z for Newspaper-Offset



**Betz Ink Supply Systems  
for Sheet-fed presses**



Complete installations, maintenance and repair work by our experienced service and assembly team



**Betz Flow GmbH**

Am Obereicholz 4  
97828 Marktheidenfeld  
Germany

Phone: +49 (0) 9391 98 26 – 0  
Fax: +49 (0) 9391 98 26 – 50  
info@betz.de  
www.betz.de

