

Original Directflo® Technology

DF50 METAL PUMPS

Air operated double diaphragm pumps for dosing, spraying, transferring, evacuating and distributing a wide variety of fluids.

Ideal for standard applications with small to medium flow rates.

Very robust metal pumps designed for the toughest applications.

Fully groundable ATEX certified pumps for use in potentially explosive atmospheres (Ex II2 GD IIB/IIC 95 °C).

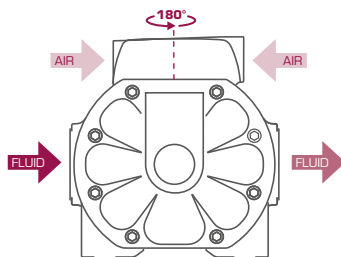

Orientable air inlet, increased installation flexibility.

1/2"
50 l/min
14 US gal/min



RECOMMENDED MODELS

MODEL	PUMP BODY	DIAPHRAGMS	BALLS	SEATS	OTHER WETTED MATERIALS	RECOMMENDED APPLICATIONS	
DF50AASNSNBAS	Aluminium	Buna-N	Buna-N	Stainless Steel	-	ATEX pump. Coolant, new and waste oil cutting, fluids, diesel.	Ex
DF50AASVSTHBAS	Aluminium	TPE	PTFE	Stainless Steel	FKM	ATEX pump. Coolant, oil, cutting fluids. Water and Ph neutral aqueous solutions. Bilge water.	Ex
DF50AASESTMBAS	Aluminium	Santoprene®	PTFE	Stainless Steel	EPDM	ATEX pump. Water based flexo and gravure inks and paints. Some types of glue.	Ex
DF50AASTSTTBAS	Aluminium	PTFE	PTFE	Stainless Steel	-	ATEX pump. Chemicals compatible with stainless steel and aluminium. Solvents (ketones, acetates and aldehydes, aliphatic and aromatic hydrocarbons) and solvent based paint, inks and varnishes. NOT FOR CHLORINATED HYDROCARBON SOLVENTS.	Ex
DF50AASTSSTBAS	Aluminium	PTFE	Stainless Steel	Stainless Steel	-	ATEX pump. Chemicals compatible with stainless steel and aluminium. Solvents (ketones, acetates and aldehydes, aliphatic and aromatic hydrocarbons) and solvent based paint, inks and varnishes. Stainless steel balls allow its use with higher viscosity fluids. NOT FOR CHLORINATED HYDROCARBON SOLVENTS.	Ex
DF50ASSTSTTBAS	Stainless Steel	PTFE	PTFE	Stainless Steel	-	ATEX pump. Chemicals compatible with stainless steel. Solvent based paint, inks and varnishes.	Ex
DF50ASSTSSTBAS	Stainless Steel	PTFE	Stainless Steel	Stainless Steel	-	ATEX pump. Chemicals compatible with stainless steel. Solvent based paint, inks and varnishes. Stainless steel balls allow its use with higher viscosity fluids.	Ex

WARNING: DO NOT USE aluminium body pumps with halogenated hydrocarbon solvents.

DF50 METAL PUMPS

TECHNICAL DATA

Pressure ratio	1:1
Maximum free delivery (1)	50 l/min (14 US gal/min)
Delivery per stroke approx. (1)	0,1 litres (0.026 US gal)
Delivery per cycle (2 x strokes) (1)	0,25 litres (0.05 US gal)
Air pressure operating range	1,5 to 8 bar (22 to 115 psi)
Solids in suspension max. size	3 mm (1/8")
Maximum dry suction lift (1)	6 m (20')
Maximum wet suction lift (1)	8 m (26')
Weight	3,5 kg (7.72 lb)
Fluid inlet connection	1/2" NPSM (F)
Fluid outlet connection	1/2" NPSM (F)
Air inlet connection	3/8" NPSM (F)
Wetted part materials	See recommended models

(1) Data measured with water, air inlet pressure 7 bar (100 psi), 20 °C (68 °F).

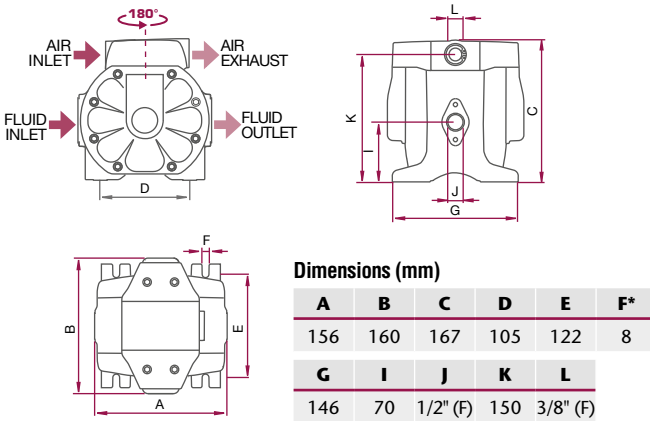

* Diameter of the holes for fasteners in each of the four pump feet.

PERFORMANCE CURVES

Tested at room temperature, with water and flooded pump with 800 mm (31 1/2") height of water above the pump inlet.

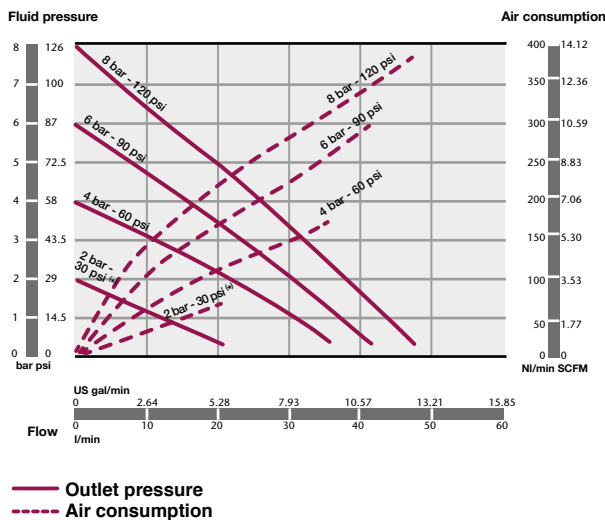

(*) 2 bar test with a pump fitted with PTFE (Teflon®) diaphragms.

DF50 METAL PUMP CODING SYSTEM

1	2	3	4	5	6	7	8	9	10
DF50	A	A	S	N	S	N	N	B	AS

1 PUMP SIZE
DF50

2 AIR MOTOR: DIRECTIONAL VALVE & AIR CHAMBER COVERS
A = Aluminium

3 WETTED PUMP BODY
A = Aluminium
S = Stainless Steel AISI 316

4 PUSH ROD
S = Stainless Steel AISI 420

5 SEALS
N = Buna-N
V = FKM (Viton®)
E = EPDM
T = PTFE (Teflon®)

6 CHECK VALVE SEATS
S = Stainless Steel AISI 316

7 CHECK VALVE BALLS
T = PTFE (Teflon®)
N = Buna-N
S = Stainless Steel AISI 316

8 DIAPHRAGMS
T = PTFE (Teflon®)
N = Buna-N

H = TPE (Hytrel®)
M = Santoprene®

9 FLUID CONNECTION THREADS
B = BSP
N = NPT

10 OPTIONS
AS = Standard pump
BS = Remote air exhaust
ES = Externally driven
FS = Extra muffler
GS = NPN inductive external pump control sensor.
IS = ATEX inductive external pump control sensor.
JS = PNP inductive external pump control sensor
US = Special UV ink pump

